

Mohr's circle for principle moment of inertia:

رجاء لكل من استخدم هذه المذكرات الدعاء لابني أيمن بالشفاء من كل داء

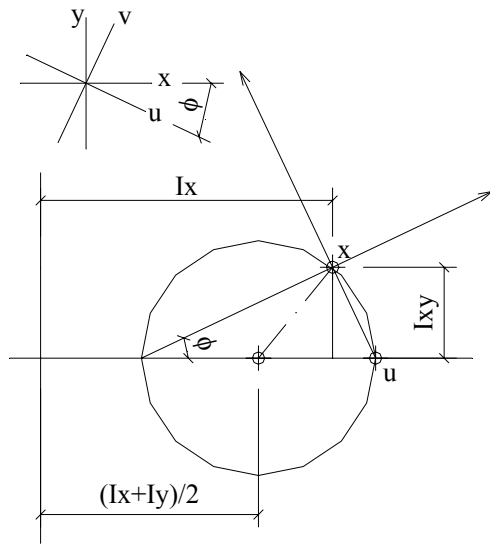

$I_x > I_y$ & I_{xy} is positive

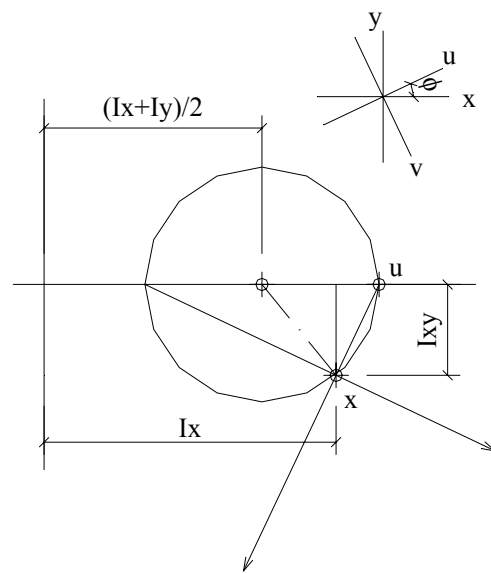

$I_x > I_y$ & I_{xy} is negative

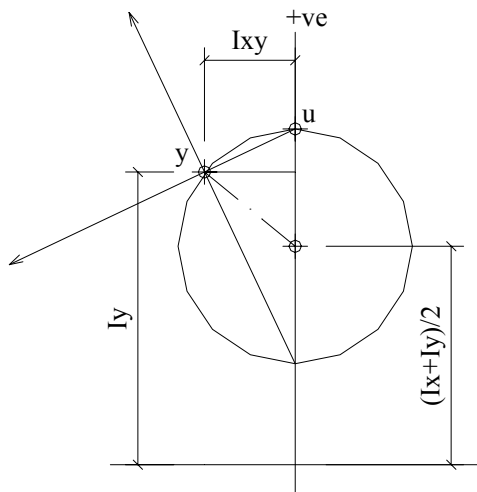

$I_y > I_x$ & I_{xy} is positive

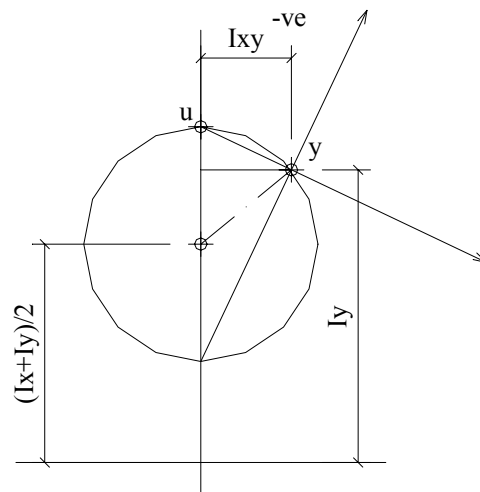

$I_y > I_x$ & I_{xy} is negative

General form of Normal Stress:

For symmetrical section, $I_{xy} = 0$, but for general cases, if the cross section is unsymmetrical, the product of inertia I_{xy} will have a value.

The general equation of stress is:

$$\sigma = \frac{N}{A} + \frac{M_Y I_X - M_X I_{XY}}{I_X I_Y - I_{XY}^2} X + \frac{M_X I_Y - M_Y I_{XY}}{I_X I_Y - I_{XY}^2} Y$$

$$\sigma = \frac{N}{A} + \frac{(N \cdot e_X) I_X - (N \cdot e_Y) I_{XY}}{I_X I_Y - I_{XY}^2} X + \frac{(N \cdot e_Y) I_Y - (N \cdot e_X) I_{XY}}{I_X I_Y - I_{XY}^2} Y$$

$$\sigma = \frac{N}{A} + \frac{N[e_X \cdot I_X - e_Y \cdot I_{XY}]}{I_X I_Y - I_{XY}^2} X + \frac{N[e_Y \cdot I_Y - e_X \cdot I_{XY}]}{I_X I_Y - I_{XY}^2} Y$$

$$\sigma = \frac{N}{A} \left[1 + \frac{A[e_X \cdot I_X - e_Y \cdot I_{XY}]}{I_X I_Y - I_{XY}^2} X + \frac{A[e_Y \cdot I_Y - e_X \cdot I_{XY}]}{I_X I_Y - I_{XY}^2} Y \right]$$

For the neutral axis, the stresses are equal to zero; i.e $\sigma = 0.0$

$$1 + \frac{A[e_X \cdot I_X - e_Y \cdot I_{XY}]}{I_X I_Y - I_{XY}^2} X + \frac{A[e_Y \cdot I_Y - e_X \cdot I_{XY}]}{I_X I_Y - I_{XY}^2} Y = 0$$

To find the intersection of the N.A. with X-axis, put $Y=0$

$$\frac{A[e_X \cdot I_X - e_Y \cdot I_{XY}]}{I_X I_Y - I_{XY}^2} X = -1$$

$$X = \frac{I_{XY}^2 - I_X I_Y}{A[e_X \cdot I_X - e_Y \cdot I_{XY}]} \quad \dots\dots\dots (1-1)$$

$$Y = \frac{I_{XY}^2 - I_X I_Y}{A[e_Y \cdot I_Y - e_X \cdot I_{XY}]} \quad \dots\dots\dots (1-2)$$

Equations (1-1) and (1-2) give the intersection of the N.A. with the X and Y axis respectively. By analyzing those two equations, one can notice that the position of the N.A does not depend on the magnitude of the force, but on its position “ e_x & e_y ”.

If we put $I_{XY} = 0.0$ in both equations “for the case of sections have an axis of symmetry”, equations (1-1) and (1-2) will be reduced to

$$X = \frac{-I_Y}{A.e_x} = \frac{-i_y^2}{e_x} \quad \dots\dots\dots (1-3)$$

$$Y = \frac{-I_X}{A.e_y} = \frac{-i_x^2}{e_y} \quad \dots\dots\dots (1-4)$$

Equations (1-3) and (1-4) are valid for sections having one or more axis of symmetry. As i_x & i_y are constants, the position of the N.A depends only on the eccentricity of the force. The N.A lies in the opposite quarter of the applied force, as shown in the following figure.

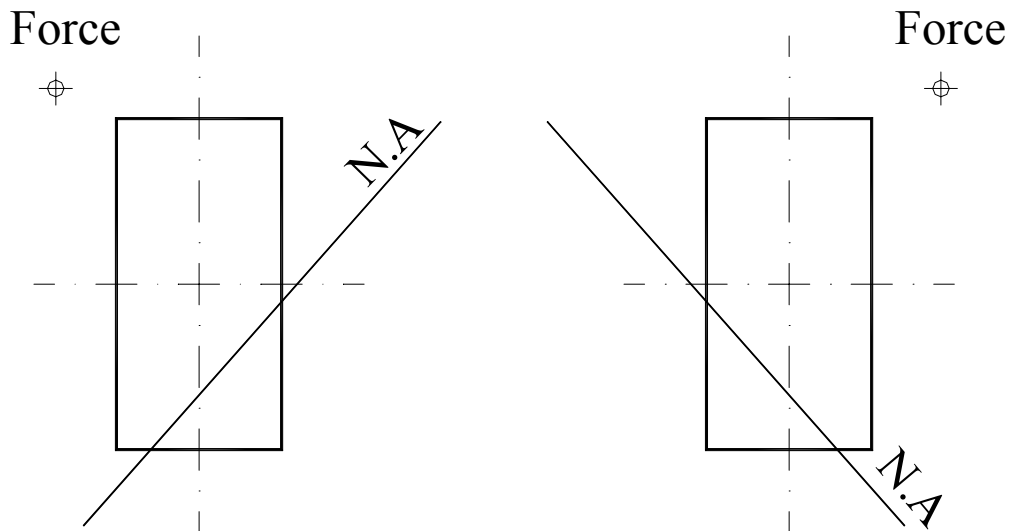

The previous fact is valid for shapes with one or more axes of symmetry, thus the two perpendicular axes X and Y through the C.G of the section are the principal axes, and the product moment of inertia $I_{xy} = 0.0$

For unsymmetrical shape, such as L-sections, the N.A may not lie in the opposite quarter to the external force.

EX. (1)

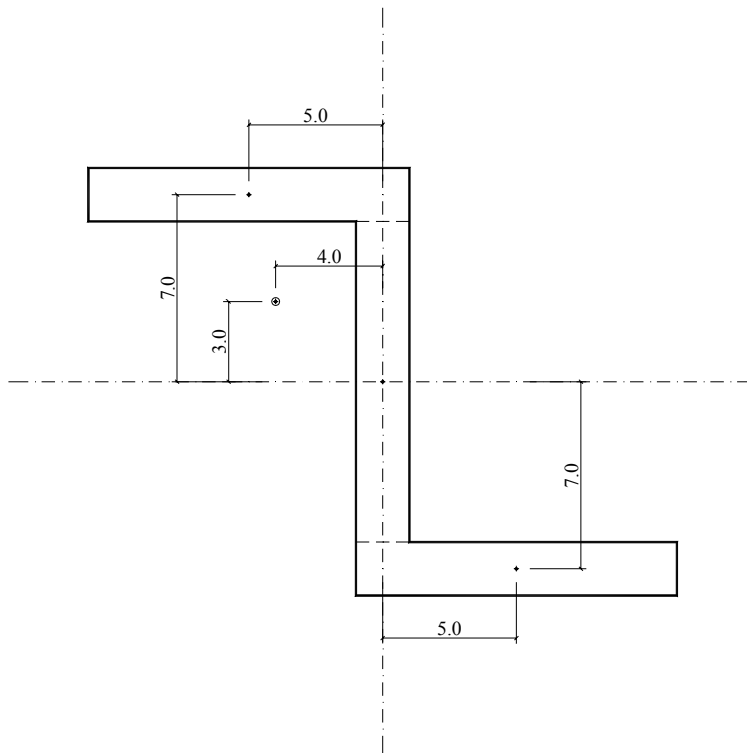

$$\text{Area} = 12 * 2 * 2 + 12 * 2 = 72.0 \text{ Cm}^2.$$

$$I_x = 2656.0 \frac{12 * 2^3}{12} * 2 + \frac{2 * 12^3}{12} + (12 * 2) * 7^2 * 2 = \text{Cm}^4.$$

$$I_y = 1784.0 = \frac{2 * 12^3}{12} * 2 + \frac{12 * 2^3}{12} + (2 * 12) * 5^2 * 2 \text{ Cm}^4.$$

$$I_{xy} = (2 * 12) * 5 * (-7) + (2 * 12) * (-5) * 7 = -1680.0 \text{ Cm}^4.$$

$$M_x = N * e_y = 3N \uparrow \text{ -Ve.}$$

$$M_y = N * e_x = 4N \leftarrow \text{ +Ve.}$$

The general equation of stress:

$$\sigma = \frac{N}{A} + \frac{M_y I_x - M_x I_{xy}}{I_x I_y - I_{xy}^2} X + \frac{M_x I_y - M_y I_{xy}}{I_x I_y - I_{xy}^2} Y$$

$$\sigma = \frac{-N}{72} + \frac{4N * 2656 + 3N * (-1680)}{2656 * 1784 - (-1680)^2} X + \frac{(-3N) * 1784 - 4N * (-1680)}{2656 * 1784 - (-1680)^2} Y$$

$$\sigma = \frac{N}{A} \left[1 + \frac{A[e_x \cdot I_x - e_y \cdot I_{xy}]}{I_x I_y - I_{xy}^2} X + \frac{A[e_y \cdot I_y - e_x \cdot I_{xy}]}{I_x I_y - I_{xy}^2} Y \right]$$

$$\sigma = \frac{-N}{72} \left[1 + \frac{72[(-4) \cdot 2656 - 3 \cdot (-1680)]}{2656 \cdot 1784 - (-1680)^2} X + \frac{72[3 \cdot 1784 - (-4) \cdot (-1680)]}{2656 \cdot 1784 - (-1680)^2} Y \right]$$

the equation of the neutral axis:

$$1 - 0.21 X - 0.0514 Y = 0$$

$$Y = 19.45 \text{ cm. \& } X = 4.76 \text{ cm.}$$

The same problem could be solved by using the principle moment of inertia.

$$I_U = \frac{I_x + I_y}{2} + \sqrt{\left(\frac{I_x - I_y}{2}\right)^2 + I_{xy}^2}$$

$$I_V = \frac{I_x + I_y}{2} - \sqrt{\left(\frac{I_x - I_y}{2}\right)^2 + I_{xy}^2}$$

$$\tan(2\theta) = \frac{-2I_{xy}}{I_x - I_y}$$

$$I_u = 3955.635 \text{ cm}^4.$$

$$I_v = 484.3469 \text{ cm}^4.$$

$$\theta = 37.7258^\circ \text{ Degree.}$$

Where θ is the angle of the principal axis (U) with respect to X-axis.

$$i_u^2 = \frac{I_u}{A} = \frac{3955.635}{72} = 54.94 \text{ cm}^2.$$

$$i_v^2 = \frac{I_v}{A} = \frac{484.3469}{72} = 6.727 \text{ cm}^2.$$

$$U_n * E_u = -i_v^2$$

Where

- U_n length of intersection between the N.A and the U-axis
- E_u eccentricity of the force with respect to the U-axis

From the principles of axes rotation:

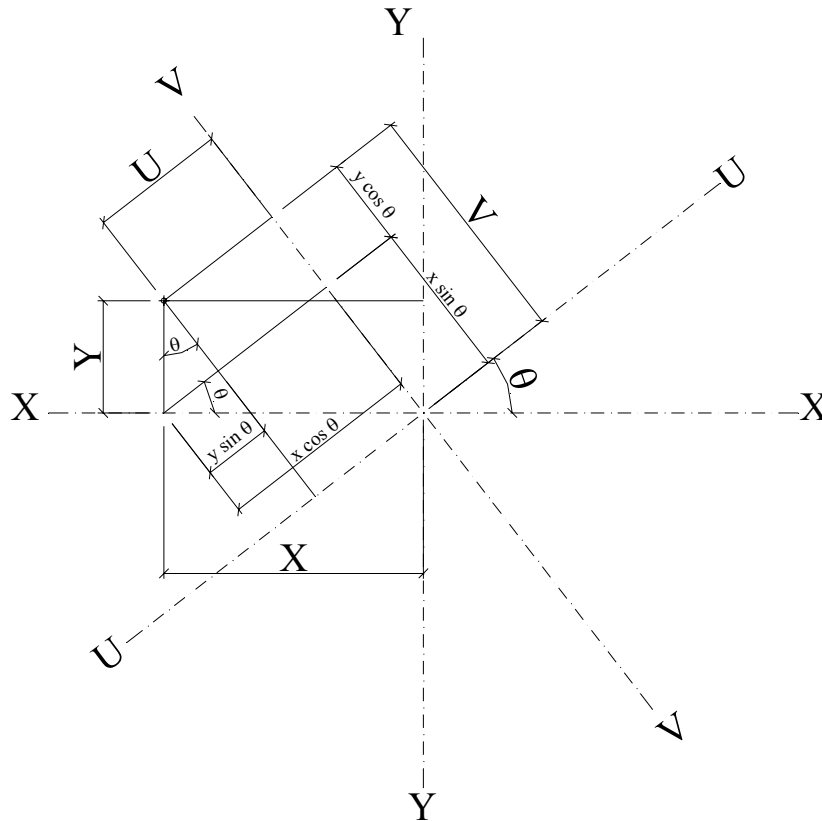

$$E_u = X \cos \theta - Y \sin \theta = -1.33$$

$$E_v = X \sin \theta + Y \cos \theta = 4.82$$

$$U_n = \frac{-i_v^2}{E_u}$$

$$U_n = -6.727 / (-1.33) = 5.058 \text{ cm}$$

$$V_n = \frac{-i_u^2}{E_v}$$

$$V_n = -54.94 / (4.82) = -11.38 \text{ cm.}$$

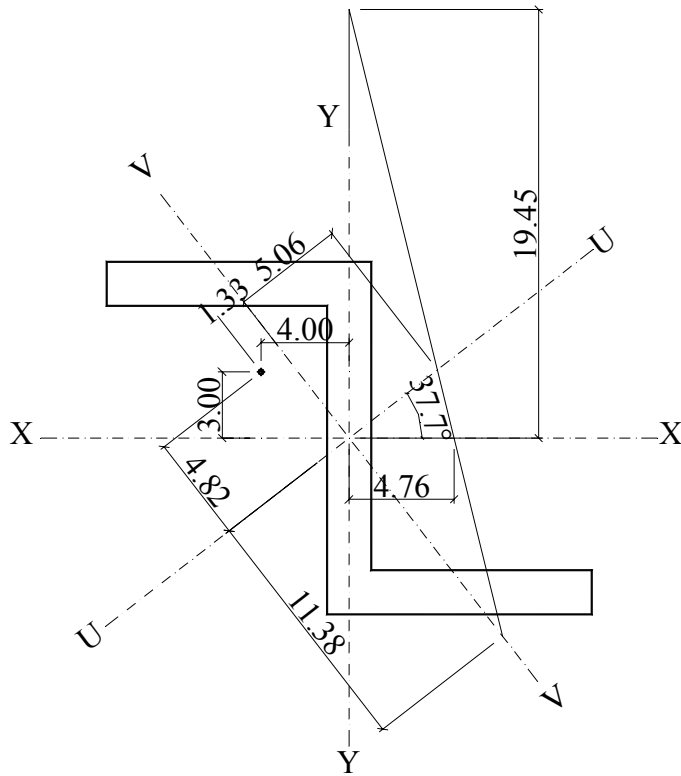

From the above equations and figures, we may conclude that the position of the N.A depends on the position of the external force with respect to the principal axes.

Core of Symmetrical Sections:

The core of the section is defined as the enclosed area within the section boundaries where which if the external force is applied inside it, the whole section is subjected to one kind of stresses, i.e (tension or compression). If the external force is applied at the core boundary, the neutral axis will be tangent to the section boundary, and the minimum stress of the section will be zero.

To locate the core of symmetrical sections, consider the external boundaries of the section as neutral axes, and then find the corresponding point of applied force.

For example, consider the rectangular section shown, consider the member (ab) to be the neutral axis, the equation of the straight line (ab) is: $X = b/2$

But, the equation of the N.A is:

$$\sigma = \frac{N}{A} \left[1 + \frac{A[e_x]}{I_y} X + \frac{A[e_y]}{I_x} Y \right]$$

$$1 + \frac{A.e_x}{I_y} X + \frac{A.e_y}{I_x} Y = 0.0$$

$$1 + \frac{e_x}{i_y^2} X + \frac{e_y}{i_x^2} Y = 0.0 \text{ which represents the equation of the N.A.}$$

$$\text{at } X = 0.0, Y = -\frac{i_x^2}{e_y} \quad \text{and at } Y = 0.0, X = -\frac{i_y^2}{e_x}$$

where X, and Y are the distances cutting X, and Y axes by the neutral axis. And e_x , and e_y are the co-ordinates of the external force, at which if the force is applied, the N.A. will be the line (ab).

For that rectangular section, $Y = \infty$, and $X = b/2$, thus,

$$e_x = -\frac{i_y^2}{X} = -\frac{2 \left(\frac{I_y}{A} \right)}{b} = -\frac{2}{b} \frac{d b^3}{12} \frac{1}{b.d} = -\frac{b}{6}$$

and so on....,

And you can conclude that each straight boundary of the section has its corresponding corner in the core, and every corner in the section has its corresponding straight boundary in the core. Also, the core of symmetrical section is symmetrical.

Core of Unsymmetrical Sections:

Area: 486.000

Moments of inertia: X: 12636.0

Y: 35964.0

Product of inertia: XY: -6318.0

Radii of gyration: X: 5.099

Y: 8.602

Principal moments of Inertia:

I_U : 11034.782

I_V : 37565.218

$$\tan(2\theta) = \frac{-2I_{XY}}{I_X - I_Y} = \frac{-2 * (-6318)}{12636 - 35964} = -0.5416$$

$\theta = -14.221$ Degrees.

$$1 + \frac{e_U}{i_V^2} U + \frac{e_V}{i_U^2} V = 0.0$$

$$U = \frac{X \cdot \cos \theta + Y \cdot \sin \theta}{X \cdot \sin \theta - Y \cdot \cos \theta} + X \cdot \cos \theta$$

$$e_U = -\frac{i_V^2}{U} = -\frac{37565.218 / 486}{14.445}$$

For the cross section, find:

1e- The maximum normal force N which gives maximum normal stress equals to 1.40 t/cm^2 .

$E_x = 4.0 \text{ cm}$ and $E_y = 2.0 \text{ cm}$, then draw the normal stress distribution.

vo- Shear stress in the rivets due to shearing force $Q_y = 25.0 \text{ t}$, where $\Phi = 23.0 \text{ mm}$ and pitch = 10 cm .

ree- Principle stress at point "n".

The cross section is composed of:

One plate $600 \times 10 \text{ mm}$, 4 plates $200 \times 10 \text{ mm}$, and 2 web plates $700 \times 10 \text{ mm}$.

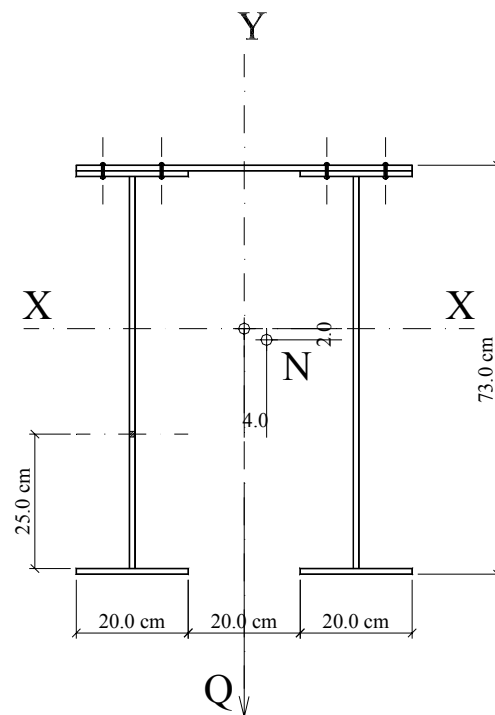

Area:	280.000
Perimeter:	486.000
Centroid:	X: 30.000
	Y: 43.821
Moments of inertia:	X: 220804.405
	Y: 108678.333
Radii of gyration:	ix: 28.082
	iy: 19.701

to find the position of the neutral axis, we can apply the equations:

$$X_n \cdot E_x = -(iy)^2$$

$$Y_n \cdot E_y = -(ix)^2$$

$$X_n = -(19.701)^2/4 = -97.032$$

$$Y_n = -(28.082)^2/(-2) = 394.3$$

$$\begin{aligned} \text{The slope of the N.A} &= \tan^{-1} Y_n / X_n = \tan^{-1} (394.3/-97.032) \\ &= 76.175 \text{ Degree.} \end{aligned}$$

$$\sigma = \frac{N}{A} \left[1 + \frac{A[e_x]}{I_y} X + \frac{A[e_y]}{I_x} Y \right]$$

$$1.4 = \frac{N}{280.0} \left[1 + \frac{280[4.0]}{108678.33} (30) + \frac{280[-2.0]}{220804.405} (-43.821) \right]$$

$$N = 275.9966 = 275.0 \text{ t}$$

$$\sigma_1 = \frac{N}{A} \left[1 + \frac{A[e_x]}{I_y} X_1 + \frac{A[e_y]}{I_x} Y_1 \right]$$

$$\sigma_1 = \frac{275.0}{280.0} \left[1 + \frac{280[4.0]}{108678.33} (-30.0) + \frac{280[-2.0]}{220804.405} (29.179) \right]$$

$$\sigma_1 = \frac{-275.0}{280.0} (0.765) = -0.7511 \text{ t/cm}^2$$

$$\sigma_2 = \frac{-275.0}{280.0} \left[1 + \frac{280[4.0]}{108678.33} (30.0) + \frac{280[-2.0]}{220804.405} (-43.821) \right] = -1.395 \text{ t/cm}^2$$

The normal stress distribution is shown in the following figure.

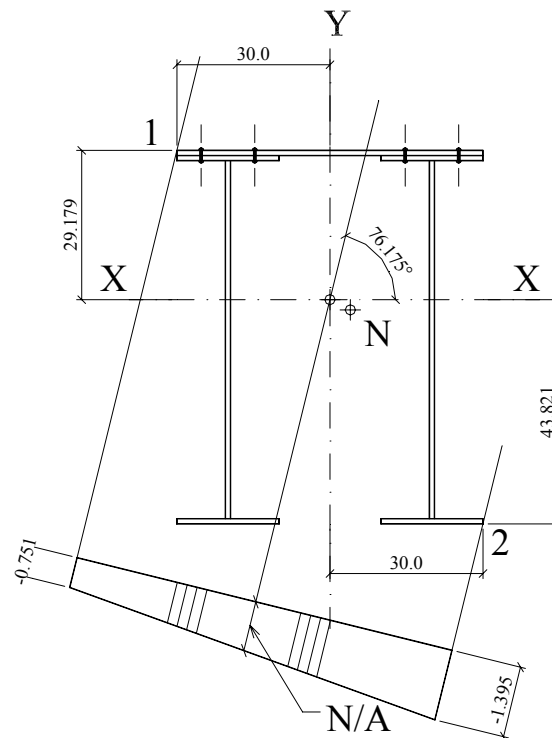

b- Shear stress in rivets

The rivets transfer the load between the upper flange plate (600x10 mm) and the two flange plates of the composed I beams.

$$\text{Shear flow at this section} = \frac{Q.S}{I_x}$$

$$S = 60.0 * 1 * (29.179 - 0.5) = 1720.74 \text{ cm}^3.$$

$$\tau = \frac{25 * 1000 * 1720.74}{220804.405} = 194.826 \text{ kg./cm}$$

force = shear flow * pitch

$$\text{force/rivet} = 194.826 * 10/4 = 487.065 \text{ kg}$$

$$\text{area of a rivet (circle of 2.3 cm diam.)} = \frac{\pi 2.3^2}{4} = 4.15 \text{ cm}^2$$

$$\text{shear stress in rivet} = \text{force} / \text{area} = 487.065 / 4.15 = 117.231 \text{ kg. / cm}^2.$$

Four- Shear stress at point (n):

$$q_n = \frac{Q.S_n}{I_x.b}$$

$$S_n = (20.0 * 1.0 * 43.321 + 24.0 * 1.0 * 30.821) * 2.0 = 3212.248 \text{ cm}^3.$$

$$q_n = \frac{25.0 * 1000 * 1556.0}{220804.405 * 2.0} = 181.849 \text{ kg/cm}^2$$

Note

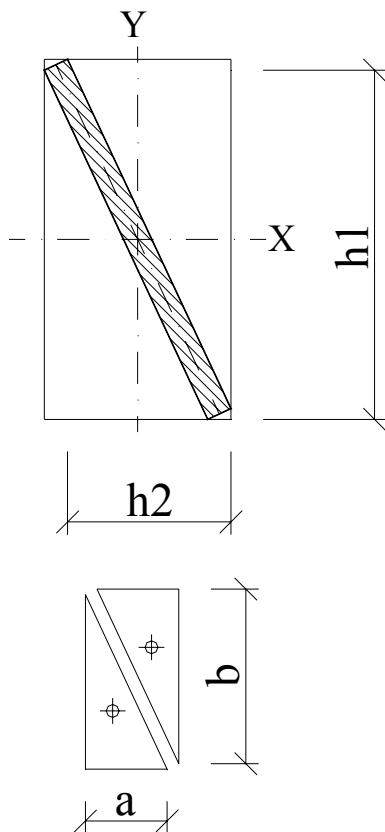

Fig. 1

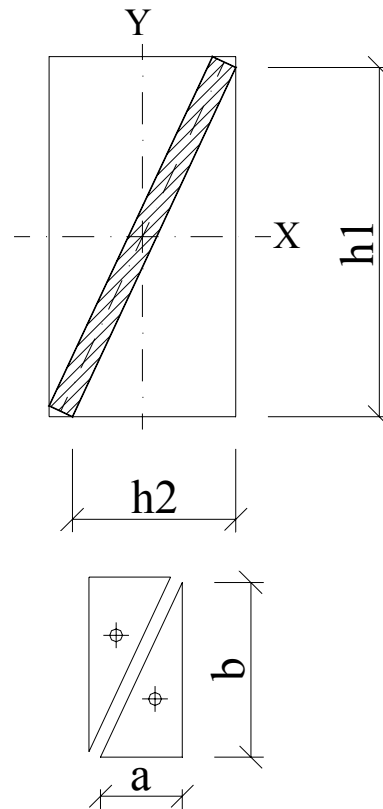

Fig. 2

For the two triangles shown in Fig. 1

$$I_{XY} = -\frac{a^2 \cdot b^2}{72} \text{ for a single one}$$

and the two triangles shown in Fig. 2

$$I_{XY} = +\frac{a^2 \cdot b^2}{72} \text{ for a single one}$$

thus, to find the inertia of a thin inclined bar shown in the two figures:

$$I_x = \frac{A \cdot h_1^2}{12} \quad \text{and} \quad I_y = \frac{A \cdot h_2^2}{12} \quad \text{for both bars shown in figures 1 and 2}$$

$$I_{XY} = -\frac{A \cdot h_1 \cdot h_2}{12} \text{ for the bar in Fig. 1} \quad \text{and} \quad I_{XY} = +\frac{A \cdot h_1 \cdot h_2}{12} \text{ for the bar in Fig. 2}$$

Where A is the cross sectional area of the bar

Deflection

1- For the cantilever beam shown in Fig. (1), find the position of maximum positive B.M. and also find the maximum deflection for the part L, and the part C.

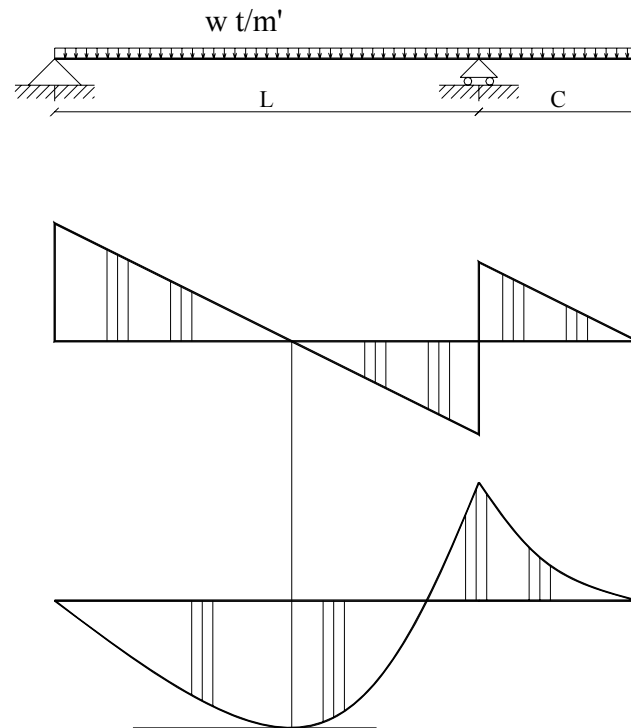

$$w = 1.5 \text{ t/m'}$$

$$L = 8.0 \text{ m}, C = 3.0 \text{ m}$$

$$EI = 2500 \text{ m}^2 \cdot \text{t}$$

Solution:

Reactions:

$$R_{\text{left}} = (1.5 \cdot 11 \cdot 2.5) / 8 = 5.156 \text{ t}$$

$$R_{\text{right}} = (1.5 \cdot 11 \cdot 5.5) / 8 = 11.344 \text{ t}$$

Equation of shear at a distance = x from the left support:

$$Q = 5.156 - 1.5x$$

$$M = \int Q \cdot dx$$

$$M = \int (5.156 - 1.5x) \cdot dx$$

$$M = 5.156x - 0.75x^2 + \text{const.}$$

At $x = 0$, $M = 0.0$, then the const. = 0.0

Point of Max. B.M. occurs at the point of zero shear.

$$Q = 0.0, x = 5.156/1.5 = 3.4375 \text{ m}$$

Max. B.M., substituting $x = 3.4375$ in the B.M. equation

$$M_{\max.} = 5.156 * 3.4375 - 0.75 (3.4375)^2 = 8.8623 \text{ m.t}$$

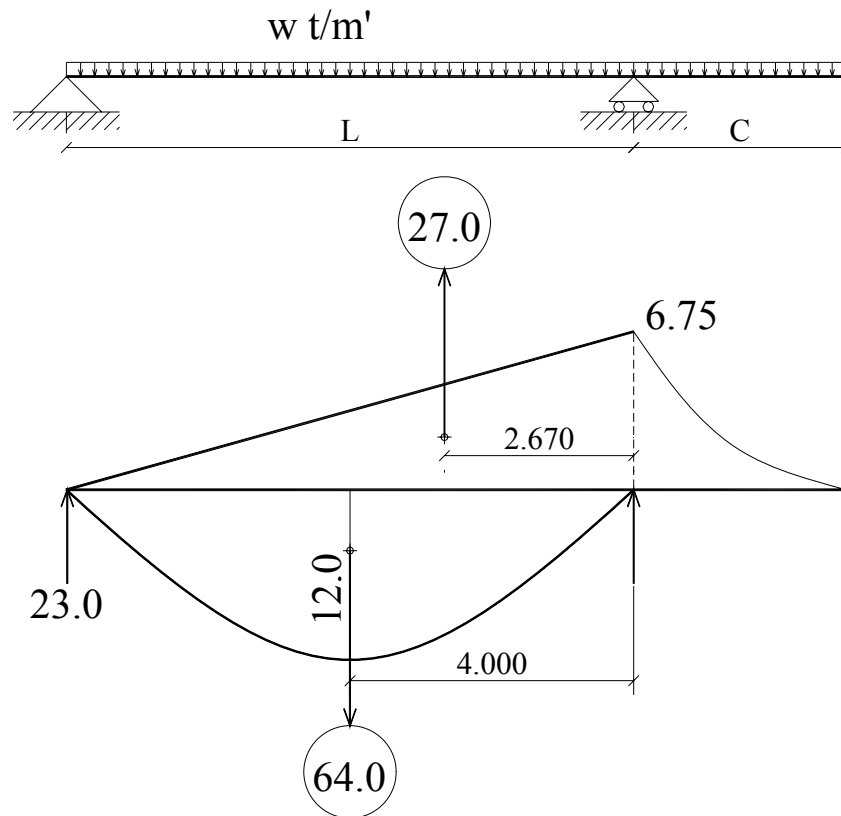

To find the maximum deflection for the part L, the B.M.D. is considered as an elastic load.

$$W_e = 5.156 x - 0.5 x^2$$

$$\text{Slope} = \int -W_e . dx$$

$$\text{Slope} = 0.167 x^3 - 2.578 x^2 + \text{const.}$$

At $x = 0.0$, the slope equals to the (Elastic Reaction)

$$\text{Const.} = 23.0$$

$$\text{Slope} = 0.167 x^3 - 2.578 x^2 + 23.0$$

This third degree equation could be solved by iteration using Newton's method.

By iteration, $x = 3.378$ m

$$\text{Deflection} = \int \text{Slope} .dx$$

$$\delta = \int \alpha .dx$$

$$\delta = \int (0.167 x^3 - 2.578 x^2 + 23.0) .dx$$

$$\delta = 0.04167 x^4 - 0.86 x^3 + 23.0 x + \text{const.}$$

At $x = 0.0$, the deflection equals to 0.0, then the const. = 0.0

$$\delta = 0.04167 x^4 - 0.86 x^3 + 23.0 x + \text{const.}$$

Substituting x with 3.378 in the deflection equation:

$$\delta = 49.97 / (EI) = 1.998 \text{ Cm.}$$

Frame Deflection

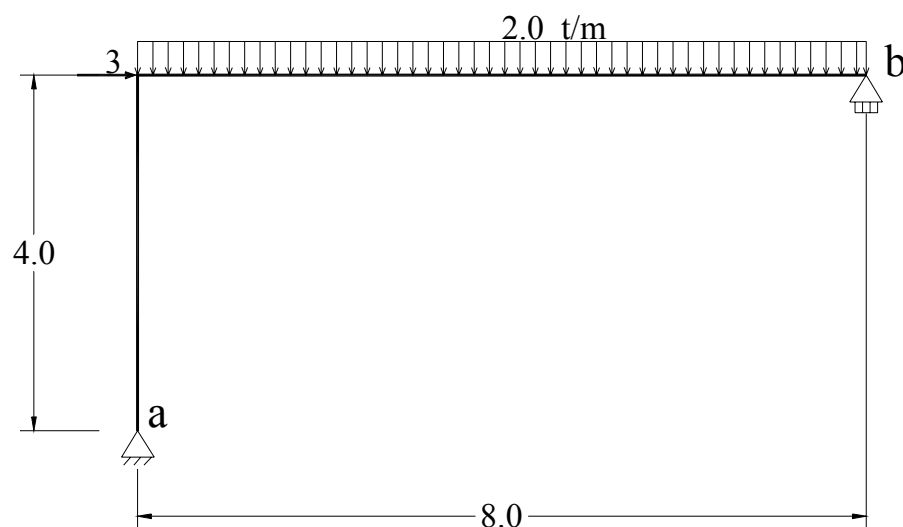

First we determine the reactions at (a and b).

$$\sum M \text{ at } a = 0.0$$

$$3.0 * 4 + 2.0 * 8.0 * 4.0 = 8.0 * Y_b$$

$$Y_b = 9.50 \text{ t}$$

$$\sum X = 0.0$$

$$X_a = 3.0 \quad \leftarrow$$

$$\sum M \text{ at } b = 0.0$$

$$2.0 * 8.0 * 4.0 - 3.0 * 4.0 = 8.0 * Y_a$$

$$Y_a = 6.50 \text{ t.}$$

The bending moment diagram is displayed in the next figure.

We find the area of each shape and concentrate it in its C.G

- 1- area of triangle (1) = $12.0 * 4.0 * 0.5 = 24.0$
- 2- area of triangle (2) = $12.0 * 8.0 * 0.5 = 48.0$
- 3- area of parabola (3) = $\frac{2}{3} * 16.0 * 8.0 = 85.33$

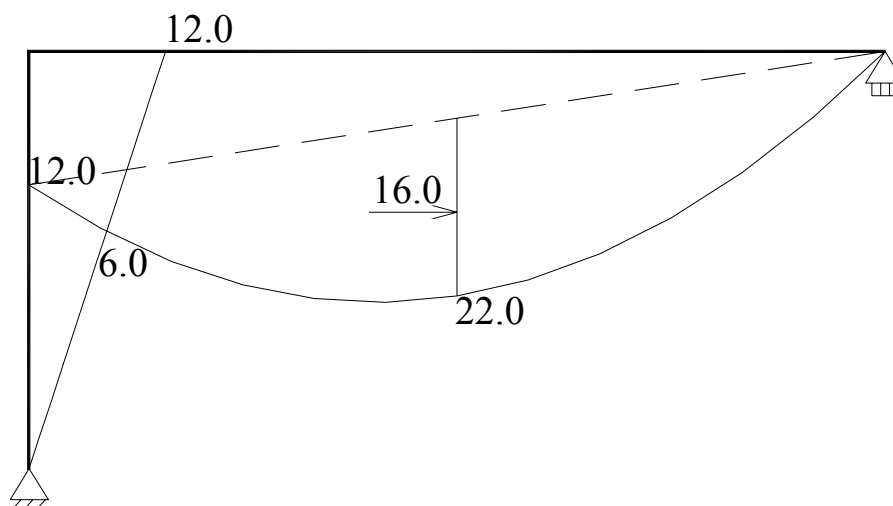

Then we have to determine the unknown displacements at the supports, which are the rotation at **a** (ϕ_a), the displacement at **b** (δ_b), and the rotation at **b** (ϕ_b).

The second step is to find the elastic reactions for the elastic loads by applying the equilibrium equations for both the elastic loads and reactions.

- 1- the **vertical** movement at **b** = 0.0, thus $\sum M$ “for vertical elastic loads” at **b** = 0.0

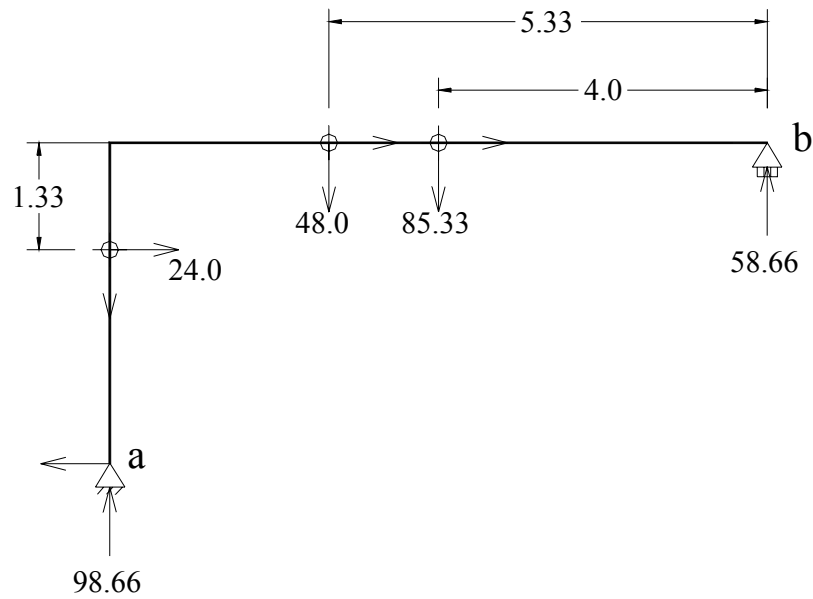

$$85.33 * 4.0 + 48.0 * 5.33 + 24.0 * 8.0 + \phi_a * 8.0 = 0.0$$

$$\phi_a = - 98.66 / EI.$$

2- the vertical movement at **a** = 0.0, thus $\sum M$ “for vertical elastic loads” at **a** = 0.0

$$48.0 * 2.66 + 85.33 * 4.0 + \phi_b * 8.0 = 0.0$$

$$\phi_b = - 58.66 / EI$$

4- the horizontal movement at **b** = 0.0, thus $\sum M$ “for horizontal elastic loads”

at **b** = 0.0

$$98.66 * 4.0 - 24.0 * 1.33 = \delta_b$$

$$\delta_b = + 362.66 / EI = 363.66/10000 = 0.03626 \text{ m} = 3.626 \text{ cm} \longrightarrow$$

Equation of 3-moments

Ex-1 Using the method of the three moments' equation, draw the normal force, shearing force and bending moment diagrams for the closed frame shown in the Fig.

$EI = \text{constant}$.

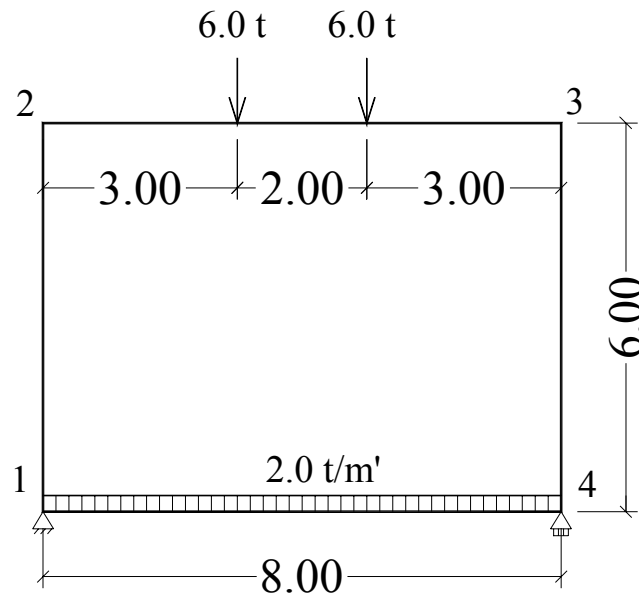

The loading of the frame is symmetrical, so the bending moment is symmetrical also.

$M_1 = M_4$ and $M_2 = M_3$.

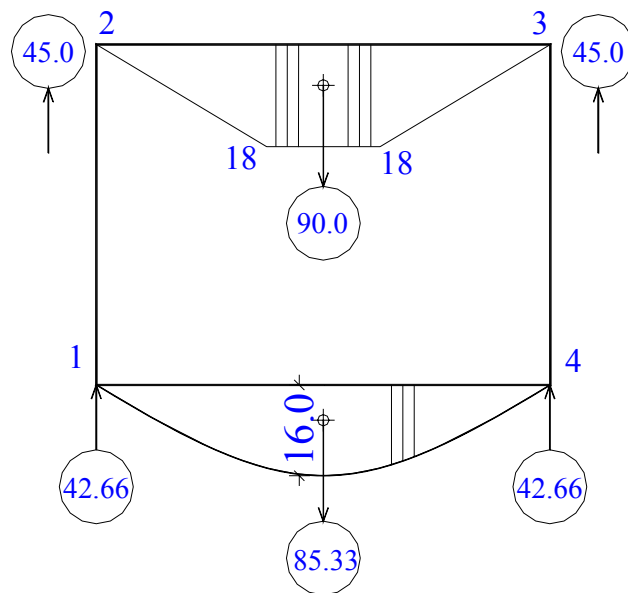

The bending moments and the elastic reactions are shown in the previous Fig.

Applying the 3-moment's equation for the points 1,2 and 3

$$M_1 (6) + 2 M_2 (6+8) + M_3 (8) = -6 (45)$$

$$6.M_1 + 28. M_2 + 8. M_3 = -270$$

but $M_2 = M_3$

$$6M_1 + 36M_2 = -270 \quad \dots\dots\dots (1)$$

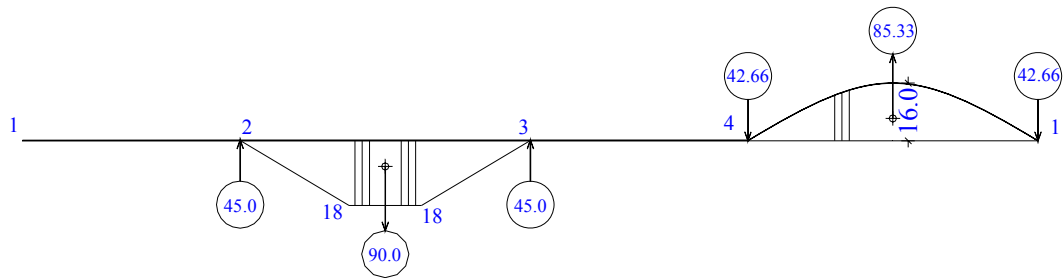

Applying the 3-moment's equation for the joints 2,3 and 4

$$M_2 (8) + 2 M_3 (6+8) + M_4 (6) = -6 (45)$$

$$8.M_2 + 28. M_3 + 6. M_4 = -270$$

but $M_4 = M_1$ and $M_3 = M_2$

$$6M_1 + 36M_2 = -270 \quad \dots\dots\dots (2)$$

which is the same equation as (1)

Applying the 3-moment's equation for the joints 3,4 and 1

$$M_3 (6) + 2 M_4 (6+8) + M_1 (8) = -6 (-42.66)$$

$$6.M_3 + 28. M_4 + 8. M_1 = 256$$

but $M_4 = M_1$ and $M_3 = M_2$

$$36.M_1 + 6.M_2 = 256 \quad \dots\dots\dots (3)$$

solving equations 1 and 3 together

$$-36.M_1 - 216.M_2 = 1620$$

$$36.M_1 + 6.M_2 = 256$$

$$-210.M_2 = 1876$$

$$M_2 = 8.9$$

Substituting this value into equation 1

$$M_1 = 8.6$$

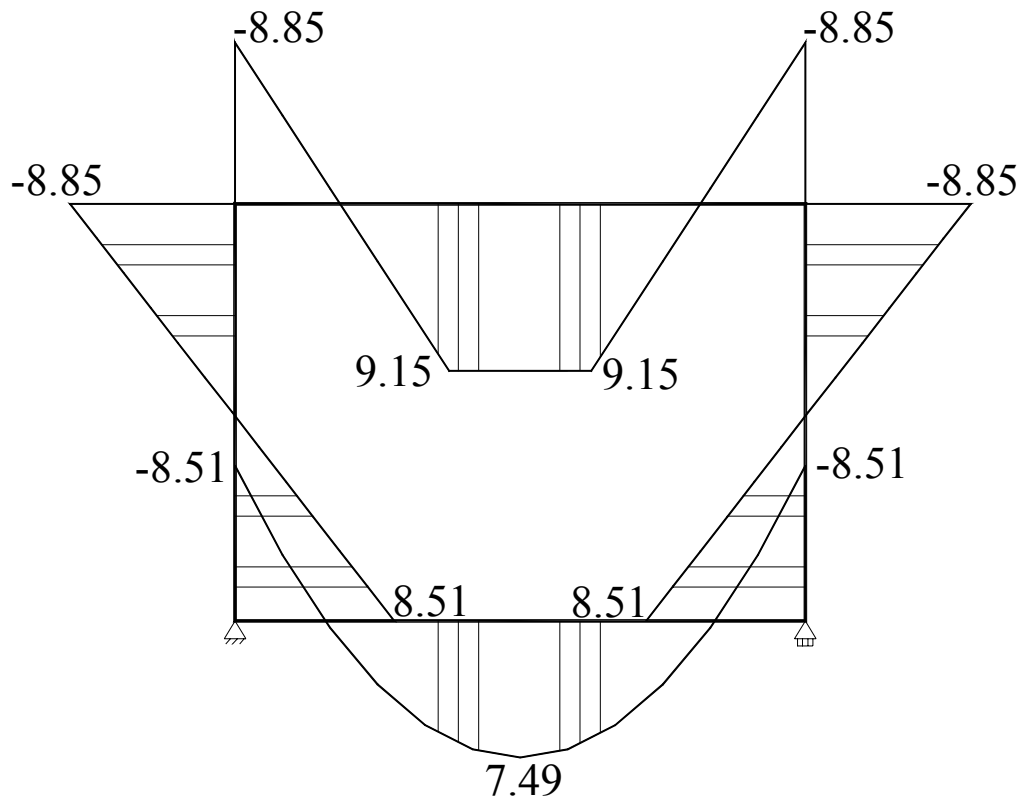

2- Draw the B.M and S.F diagrams for the fixed frame shown in the figure.

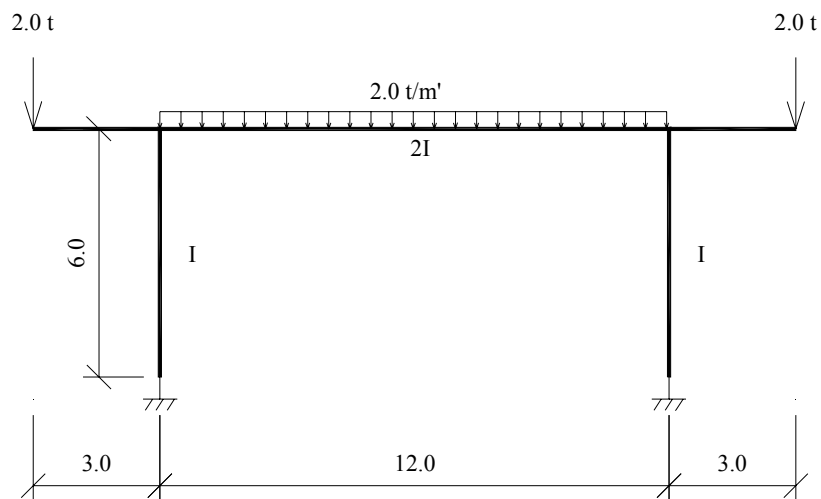

The relative moments of inertia of the members are as indicated.

This frame could be solved in three different ways leading to the same results:

- 1- the outer moment of the cantilever is applied to the beam
- 2- the outer moment of the cantilever is applied to the column
- 3- satisfy the equilibrium condition at the cantilever joint as follows:

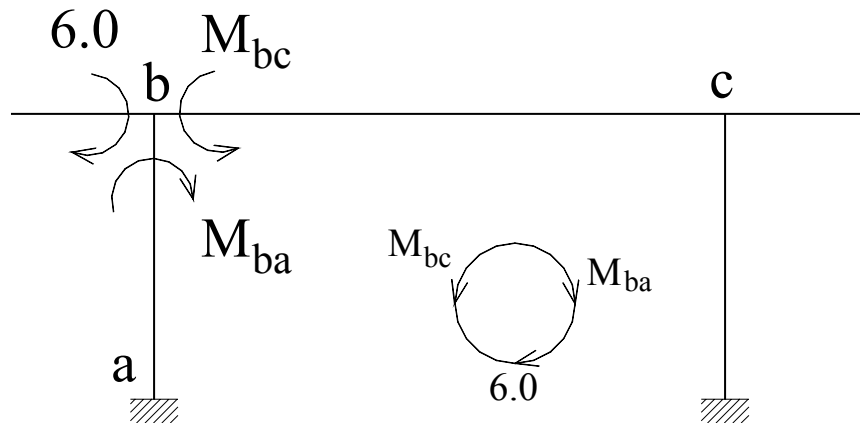

$$M_{bc} = M_{ba} + (-6.0) \quad \dots\dots\dots (1)$$

One has to note that the external moment must be taken with its sign, i.e the external moment 6.0 m.t is negative, that is because the resulting moment from the equation of three moments is sign scribed. Then the moment of the cantilever is not taken into account in calculating of elastic reaction.

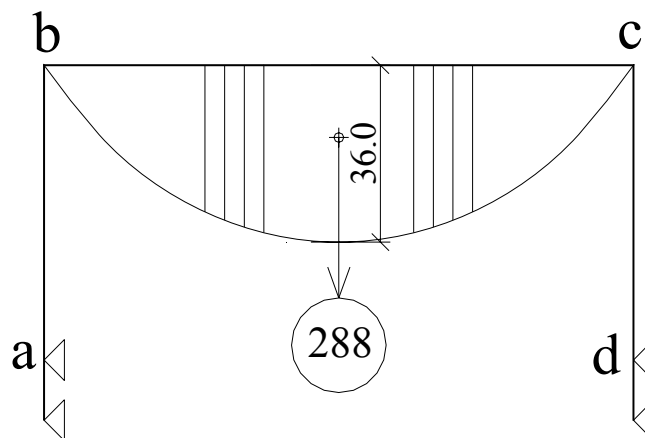

Equation of three moments at point (a)

$$2 M_a (6) + M_{ba} (6) = 0.0$$

$$2 M_a + M_{ba} = 0.0 \quad \dots\dots\dots (1)$$

Equation of three moments at point (b)

$$M_a (6/I) + 2 M_{ba} (6/I) + 2 M_{bc} (12/2I) + M_{cb} (12/2I) = -6(144/2I)$$

$$M_{bc} = M_{ba} - 6 \quad \text{and} \quad M_{cb} = M_{bc}$$

$$6.M_a + 12.M_{ba} + 12.(M_{ba} - 6.0) + 6 (M_{ba} - 6.0) = -6(72)$$

$$6.M_a + 30. M_{ba} = -324.0$$

$$M_a + 5. M_{ba} = -54.0 \quad \dots\dots\dots (2)$$

$$-M_a - 0.5 M_{ba} = 0.0 \quad \dots\dots\dots (1)$$

$$4.50 M_{ba} = -54.0$$

$$M_{ba} = -12.0 \text{ m.t}$$

$$M_{bc} = -12.0 - 6.0 = -18.0 \text{ m.t}$$

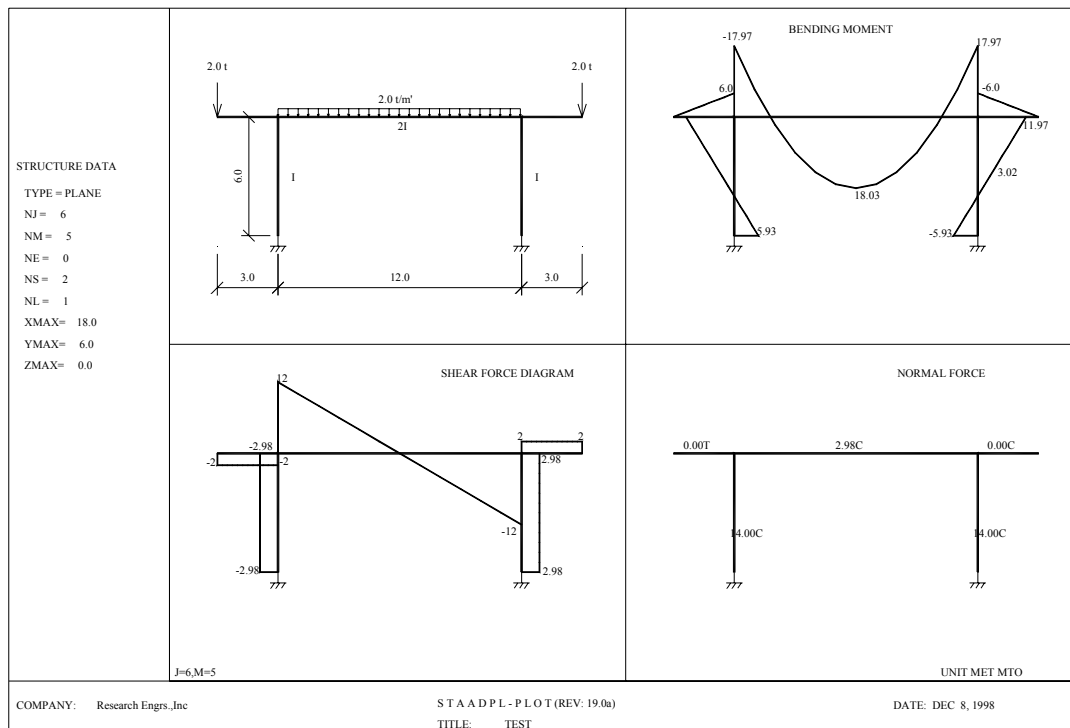

Fixed points for indeterminate continuous beams:

The fixed points are the points, which have, zero bending moment along the continuous beam when one span is loaded.

The fixed points could be determined analytically or graphically.

Analytical method

The equations obtained in this method are driven from the method of three-moments.

$$\frac{M_2}{M_1} = -\frac{2(L_1 + L_2)}{L_2} = -\left[2 + \frac{L_1}{L_2}(2)\right] = -K_2$$

where K_2 is called “the left hand *focal factor* of the second span”.

$$\frac{M_3}{M_2} = -\left[2 + \frac{L_2}{L_3}\left(2 - \frac{1}{K_2}\right)\right] = -K_3$$

$$\frac{M_4}{M_3} = -\left[2 + \frac{L_3}{L_4}\left(2 - \frac{1}{K_3}\right)\right] = -K_4$$

..
..
..
..

$$\frac{M_n}{M_{n-1}} = -\left[2 + \frac{L_{n-1}}{L_n}\left(2 - \frac{1}{K_{n-1}}\right)\right] = -K_n$$

where $K_1 = \infty$

the right hand focal length is determined using the same procedure

$$-\frac{M_{n-1}}{M_n} = \left[2 + \frac{L_{n+1}}{L_n}\left(2 - \frac{1}{\bar{K}_{n+1}}\right)\right] = \bar{K}_n$$

the connecting moment at the left and right supports of a loaded span is given by:

$$M_{n-1} = -\frac{6(L_{el} \cdot \bar{K}_n - R_{el})}{L_n(K_n \cdot \bar{K}_n - 1)}$$

where L_{el} is the left elastic reaction of the n^{th} Span.

And R_{el} is the right elastic reaction of the n^{th} Span.

$$M_n = -\frac{6(R_{el} \cdot K_n - L_{el})}{L_n(K_n \cdot \bar{K}_n - 1)}$$

if the continuous beam is loaded over the left first span, then

$$M_n = -\frac{6 \cdot R_{el}}{L_n \cdot K_n}$$

Graphical determination of Fixed points

Steps of the method:

- 1- Divide each span into three equal distances.
- 2- Draw vertical lines from these points to the left and right of the supports, the line to the left of support b is named " L_b ", and the line to the right of support b is named " R_b ", and so on.
- 3- Draw vertical lines between each "right and left" lines of each span that divide the distance between them reversibly. These lines are named " I_{support} ", which means that the line of support "b" is named " I_b ".
- 4- to determine the left fixed points, draw a line from the first left fixed point –which is the left support "a"- with any inclination to intersect with L_b and I_b in x and y.
- 5- from the point of intersection with L_b "x", draw a line to the support "b" and extend it to meet R_b in z.
- 6- draw a line connecting x and z to intersect with the center line of the continuous beam in f, which is the right fixed point of the support "b".

- 7- repeat the three previous steps from point “f” instead of point “a” to determine the remaining right fixed points of the supports.
- 8- To find the left fixed points repeat the previous steps starting from the first left fixed point which is support “f”.

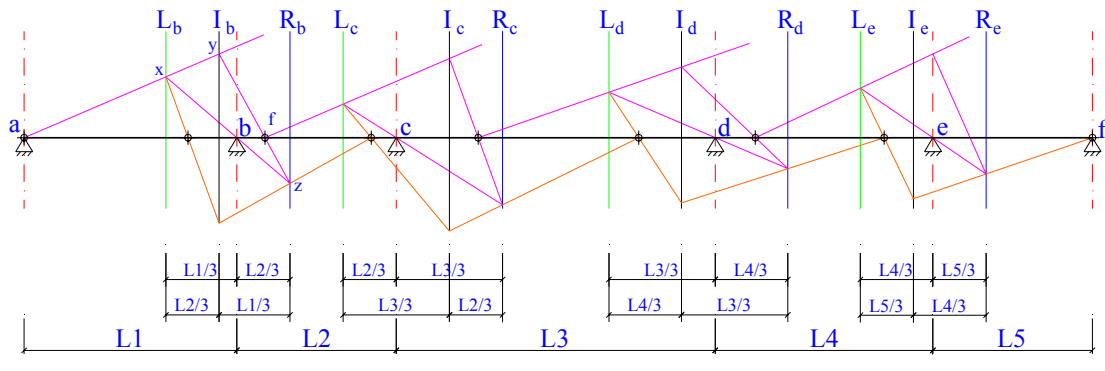
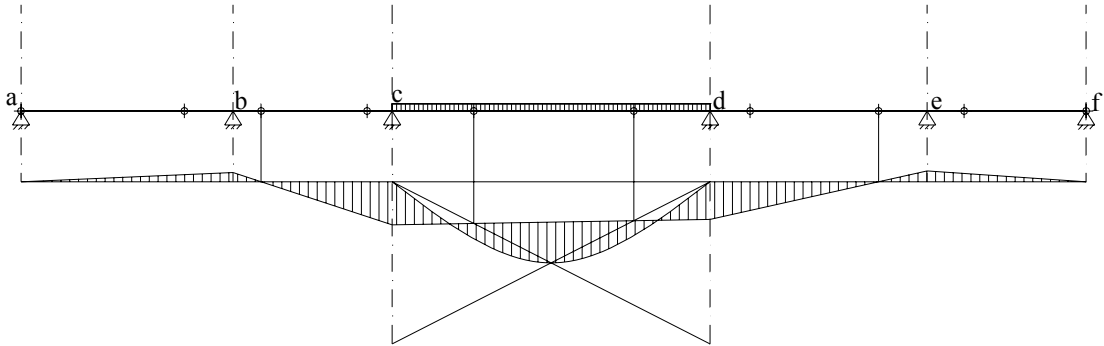

Fig. The fixed points

Connecting Moments:

Uniformly distributed load:



Single concentrated load:

